

“Coral” Set Installation Guide

For Steel Door

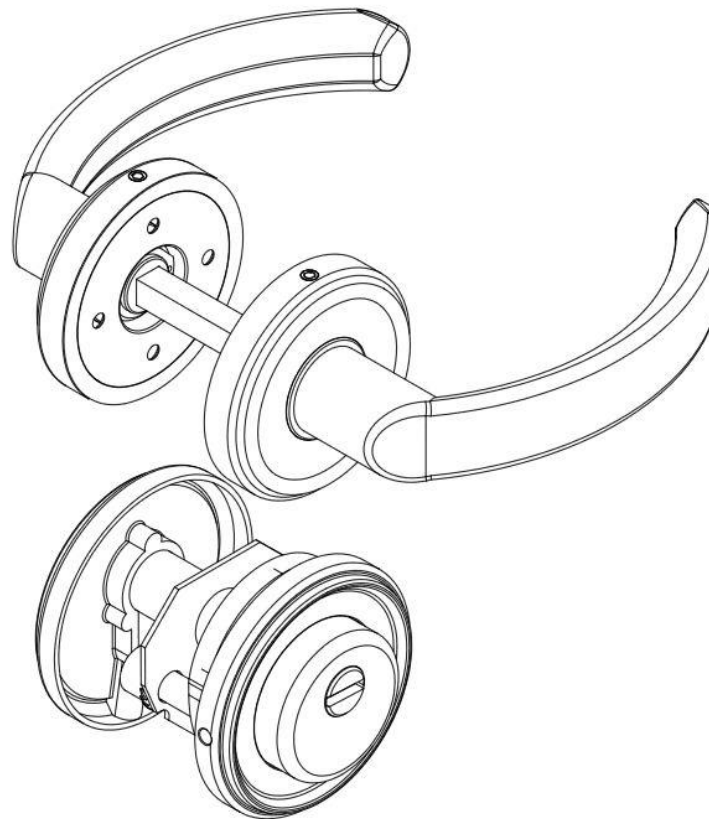

www.rav-bariach.com

Required Tools

- A – Screw Driver + Phillips Bit
- B – Phillips Screw Driver
- C – 2.5, 3, 6 Allen keys

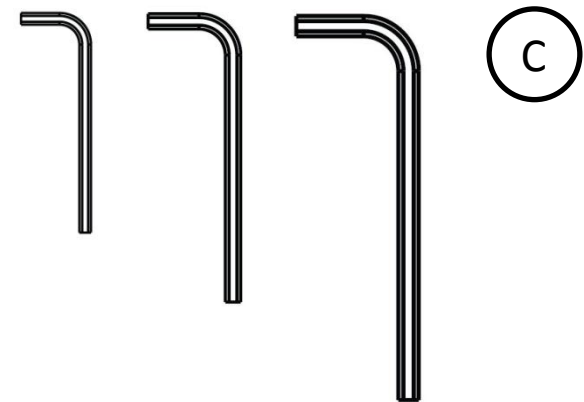
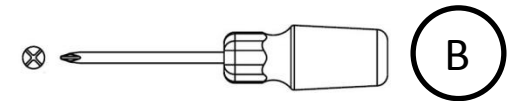
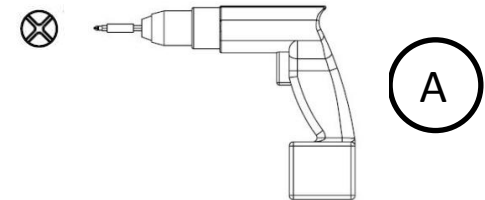

Part List

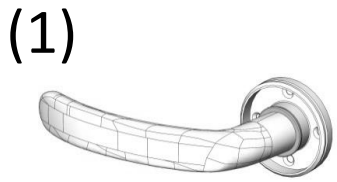

Internal/External
Connected Handle (x2)

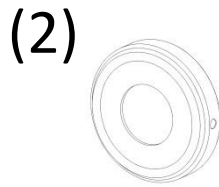

Decorative Rossete (x2)

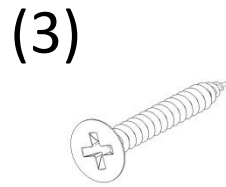

4.2x9.5 Screw (x8)

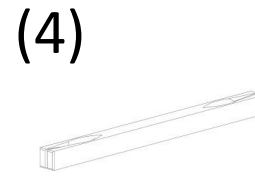

Square Spindle (x1)

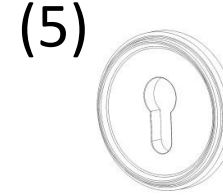

Internal Rossete (x1)

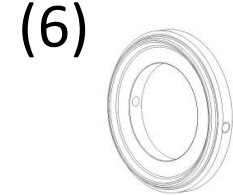

Cylinder Protector
Rossete (x1)

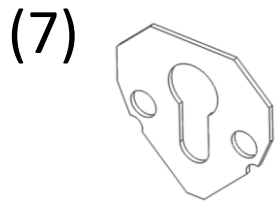

1.5mm Rossete (x1)

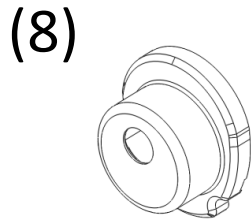

Round Cylinder
Protector(x1)

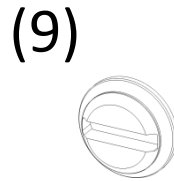

Rotating Disk (x1)

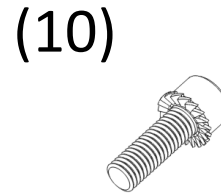

Screw DIN912
M8X25 (x2)

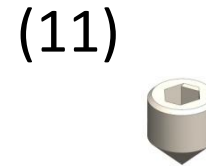

DIN 914 45H-
M5x6 (x6)

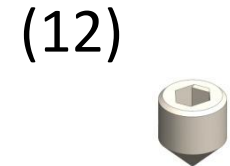

DIN 914 45H-
M5x8 (x1)

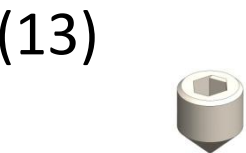

DIN914 M6X10

Hardware Installation

1

Assemble the (8) round cylinder protector with two (10) M8X25 screws

Keep the rotating disk inside the cylinder protector hole during it's insertion on the cylinder by using a key

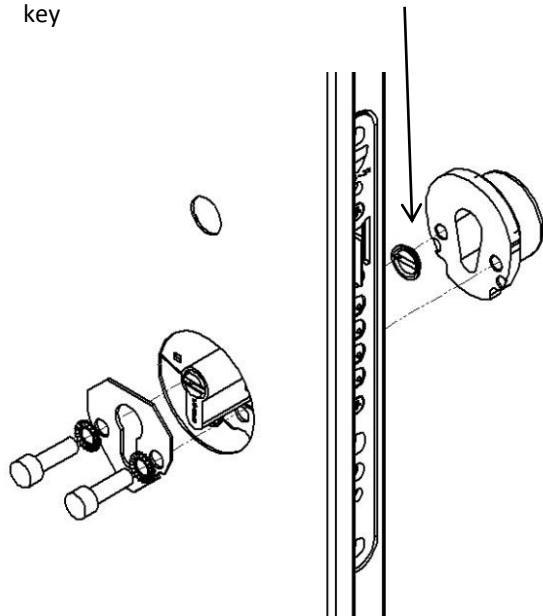

2

Assemble the (5) Internal rossete and tighten with (12) M5X8 screw

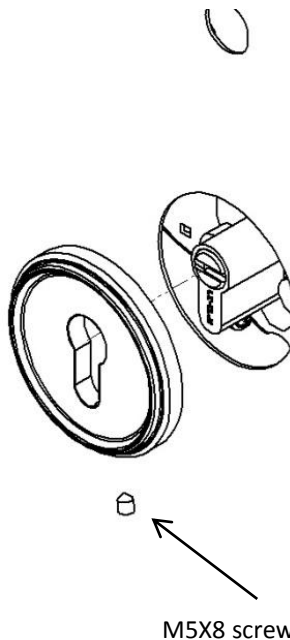

3

Assemble the (6) cylinder protector rossete and tighten with two (11) M5x6 screws

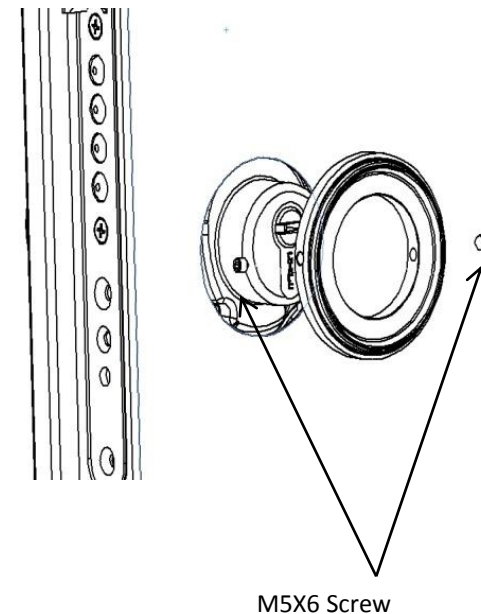

Hardware Installation

4

Insert the (4) square spindle inside the door, assemble the (1) handles and tighten with four (3) 4.2x9.5 screws each side, then tighten the two (13) M6X10 screws

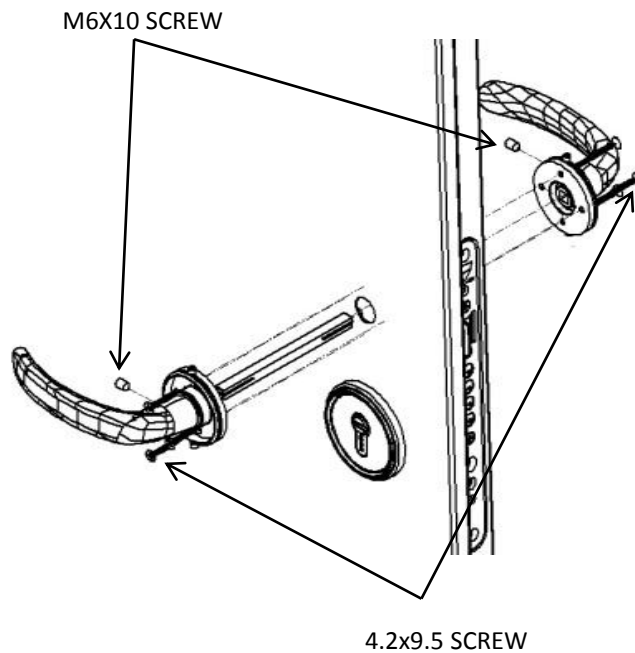

5

insert the (2) decorative rosette by sliding it on both handles

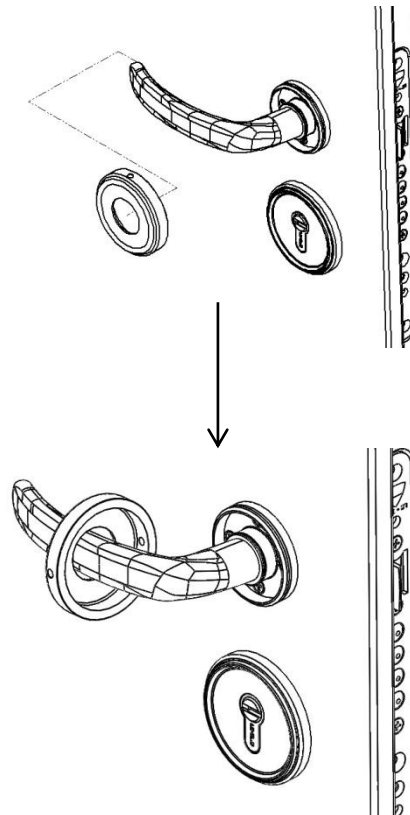

6

Tighten the two (11) M5x6 screws each side

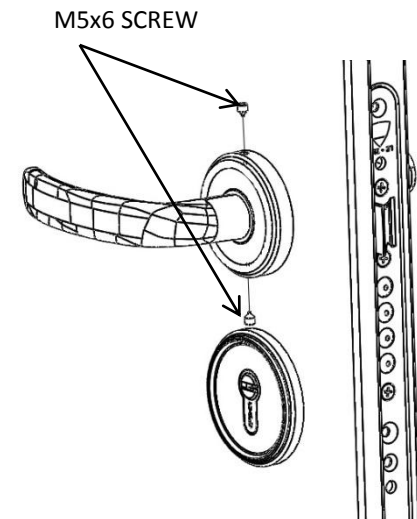

Hardware Installation

7

Final result

Note : Insure free movement of the handle and the lock mechanism

